



Fire testing procedure for concrete tunnel linings

Report no.	2008-Efectis-R0695 <i>This document supersedes TNO report 1998-CVB-R1161 (Rev. 1)</i>
Author(s)	Ir. A.J. Breunese Dr. Ir. C. Both Ir. G.M. Wolsink (Rijkswaterstaat)
Project number	2007221-103
Date of issue	September 2008
Number of pages	23

This report is the result of a joint effort between the Directorate-General of Public Works and Water Management (Rijkswaterstaat) and Efectis Nederland

CONTENTS

PREFACE	3
1. INTRODUCTION	4
1.1 spalling test	4
1.2 thermal insulation test	5
2. SPALLING TEST	6
2.1 Test specimens	6
2.1.1 <i>Geometry</i>	6
2.1.2 <i>Reinforcement</i>	6
2.1.3 <i>Casting of the specimens</i>	6
2.1.4 <i>Loading</i>	7
2.1.5 <i>Concrete mix</i>	8
2.1.6 <i>Temperature measurements</i>	8
2.2 Fire protection system	9
2.3 Conditioning of the test specimens	11
2.4 Fire test	14
2.5 Heating curve	15
2.6 Performance criteria	16
2.7 Report	17
3. THERMAL INSULATION TEST	18
3.1 Test specimens	18
3.2 Fire protection system	19
3.3 Conditioning of the test specimens	20
3.4 Fire test	20
3.5 Heating curve	20
3.6 Performance criteria	20
3.7 Report	22
APPENDIX A: NOTES CONTAINING BACKGROUND INFORMATION	23

PREFACE

The Directorate-General of Public Works and Water Management (Rijkswaterstaat, hereafter denoted as “RWS”) requires that road tunnels underneath open water in the Netherlands are resistant against a hydrocarbon-fire according to the RWS fire curve.

Recently, more specific requirements have been put forward by RWS in the Dutch document ROBK-6 “Richtlijnen voor het Ontwerpen van Betonnen Kunstwerken” (Guidelines for the design of concrete infrastructure works, version 6, Feb. 6th, 2006).

A fire test procedure has been available since 1986, when TNO published the report BI-86-69 - Tunnel Protection Fire Test Procedure, which described a test on a concrete slab with fire protection, to be exposed to the RWS fire curve.

In 1998, RWS and TNO Centre for Fire Research (now: Efectis Nederland) jointly produced the more detailed document “1998-CVB-R1161 (rev.1) - Fire Protection for Tunnels - Part 1: Fire Test Procedure”. Besides a more detailed procedure for testing fire protection systems on concrete slabs, 1998-CVB-R1161 (rev.1) also introduced a test procedure for evaluation of the spalling behaviour of concrete tunnel structures when exposed to fire.

After more than a decade of experience in fire testing of tunnel linings according to the procedure of 1998-CVB-R1161 (rev.1), RWS and Efectis Nederland have taken the initiative to develop an updated fire testing procedure for tunnel linings. There are several reasons for this, mainly:

- changes in tunnel construction practice,
- new knowledge about the fire resistance of concrete,
- practical experience after carrying out many fire tests on concrete structures,
- the increased international attention towards the test procedure and the RWS fire curve in particular.

The purpose of this report is to provide a test procedure which reflects the current state of the art and which is suitable for a practical range of tunnel construction types and fire protection systems.

This report is a co-production of RWS and Efectis Nederland. The report describes the required test specimens (geometry, loading, fire protection) and the test procedure (conditioning, heating). In an appendix, a summary of performance criteria as specified by RWS in the Dutch document ROBK-6 is given. Some background information on the main text is given by means of notes referring to appendix 1.

1. INTRODUCTION

Unprotected or insufficiently protected concrete tunnel linings can seriously be damaged during a fire in a tunnel. Many real tunnel fires over the last decade have shown that such damage is likely to result in repair works that are very costly and take the tunnel out of service for a long time. Also such damage may jeopardise (infra-)structures or buildings erected above the tunnel. To prevent or at least mitigate such damage during and after a fire, measures can be taken to protect the tunnel. Measures may aim to:

- avoid or limit spalling of concrete,
- limit temperatures or the heating rate of the concrete surface,
- limit temperatures of the reinforcement,
- limit temperatures of the concrete around the reinforcement,
- limit temperatures at the unexposed side,
- limit propagation of cracking into the cold zone.

Depending on the situation, different fire protection measures may be chosen. These measures can be basically divided into two categories:

1. measures inside the concrete (concrete mix, additives, polypropylene fibres, etc.),
2. measures outside the concrete (external fire protection systems).

Obviously, for refurbishment of existing tunnels 1 is not an option. For new tunnels, either 1 or 2 or a combination of both could be chosen.

Two different tests are defined, aiming to provide information on:

- spalling behaviour of the concrete structure (“spalling test”),
- temperatures of the concrete surface, reinforcement and other critical locations inside the concrete (“thermal insulation test”).

Generally, in a spalling test temperatures will also be measured. In that case the spalling test gives information on spalling behaviour as well as concrete temperatures.

1.1 SPALLING TEST

Spalling tests are needed to assess the suitability of a concrete structure for application in practice, given the possibility that during a fire unacceptable damage to the structure may occur due to spalling of the concrete. The test therefore comprises the concrete structure including intended measures to prevent spalling such as the application of an external fire protective layer, addition of polypropylene fibres to the concrete mix or other adjustments of the concrete formula.

The test specimens should resemble the practical situation as closely as possible, including the exact concrete mix and possible fire protection measures. A spalling test shall incorporate at least the following characteristics based on the real situation:

- concrete mix (proportions, sizes and types of all ingredients, if applicable: including the polypropylene fibres);
- representative compressive load;
- conditioning of the specimen (storage of the specimens wrapped in plastic foil; concrete age of at least 90 days at the time of testing)¹;
- if applicable: fire protection system (including application procedure, curing conditions, fixings, joints, and a low moisture content).

The phenomenon of spalling is very complex and involves a combination of physical, chemical and mechanical processes, influencing each other. This is one of the reasons why scale tests or computer modelling are considered inadequate to conclude on the spalling risk for a given situation.

It is required to do fire tests on at least two identical, large scale (preferably 1:1) test specimens. The procedure for performing a spalling test is described in chapter 2.

Besides carrying out a fire test, it may be required to demonstrate the resistance of a fire protection system against other influences such as air pressure waves, frost-thaw cycles, chemically aggressive environments etc. Such tests are not described in this document.

1.2 THERMAL INSULATION TEST

The insulation capacity of an external fire protection system can be determined by doing small-scale fire tests on a slab of at least 1,45x1,45m², of which at least 1,15x1,15m² are exposed to fire. The slab is a C30 silicious aggregate concrete slab. A high moisture content of the concrete slab should be avoided in order to avoid spalling, because spalling of concrete is not the objective of this test.ⁱⁱ

Subject of the test is the fire protection system including application procedure, curing conditions, fixings, joints, and a low (or representative) moisture content.

The test aims to:

- assess the suitability of the insulation material to withstand the temperature during a fire according to a prescribed time-temperature curve (e.g. the RWS fire curve),
- assess if the fire protection system is properly fixed to the concrete in order to prevent it from falling down during the fire,
- assess the required thickness of the insulation material in relation to the stated temperature requirements.

The procedure for performing a thermal insulation test is described in chapter 3.

Note: it is recognised that a passive fire protection system comprises the application, the material, the fixings etc. Therefore, although small, the test specimens should have a representative scale to investigate the behaviour of the complete system. Usually an exposed surface of 1.15x1.15 m² suffices, but this needs to be evaluated for the fire protection system under consideration. The chosen measure is therefore not driven by furnace dimensions.

2. SPALLING TEST

In order to have a valid test result, tests should be performed at least twice on identical specimens, with identical insulation material, thickness etc.ⁱⁱⁱ The requirements for the test specimens, fire protective materials, conditioning, fire test and reporting are described in this chapter. Because the test specimens need to resemble the real tunnel as closely as possible, the test result in principle is only valid for the tunnel project for which the test was performed.

2.1 TEST SPECIMENS

When designing a test specimen for a spalling test, a number of aspects shall be considered. These aspects are described in the following paragraphs.

2.1.1 Geometry

The geometry of the specimen shall resemble the real tunnel situation. For prefabricated segmental linings this means that full segments shall be tested, with a view to avoid unwanted (because uncontrollable, unpredictable and unrealistic) effects of artificially introduced boundaries.

For large (cast in situ) structures, a sufficiently large specimen shall be made to avoid edge effects, because spalling at the edges of a slab or wall specimen is usually less severe.

For walls and slabs, the thickness should be equal to the thickness in practice. If this thickness exceeds 0,40 m, for practical reasons it is allowed to limit the thickness of the specimen to 0,40 m.

The length and width of slab or wall specimens should be at least 6-8 times the thickness of the specimen in order to avoid edge effects.

For beams or columns, it should be considered if the beam is exposed to fire on one, two, three or four sides. The test set up should be accordingly. The heated length of the beam or column should be at least 6-8 times the width or height¹ of the cross-section.

2.1.2 Reinforcement

The steel reinforcement in the concrete shall be similar to the real tunnel situation. This applies to

- maximum bar diameter,
- minimum concrete cover,
- type of spacers,
- mesh distances.

Small amounts of additional reinforcement may be applied to guarantee proper transport and lifting as well as installation of thermocouples and application of mechanical loads. Additional reinforcement should always be discussed with the client, because of the possible influence on the results of tests. In the report a statement should be taken on this matter.

2.1.3 Casting of the specimens

The manufacturing process of the specimens shall include the correct orientation of the specimen during casting, and be as close to actual manufacturing as reasonably possible. This with a view to exclude unwanted effects of differences in the actual concrete properties. Test results indicate that the direction of casting can have a significant influence on spalling. Also the surface (material, roughness) of the formwork may be of influence.

For cast in situ structures this means that ceiling specimens shall be cast in a horizontal formwork, with the bottom (formwork) side being the one that will be exposed to fire. Wall specimens should be cast vertically.

¹ The largest value of width and height prevails.

Additionally, horizontal casting of wall specimens is allowed if the fire exposed surface during the fire test is the bottom (formwork) side.

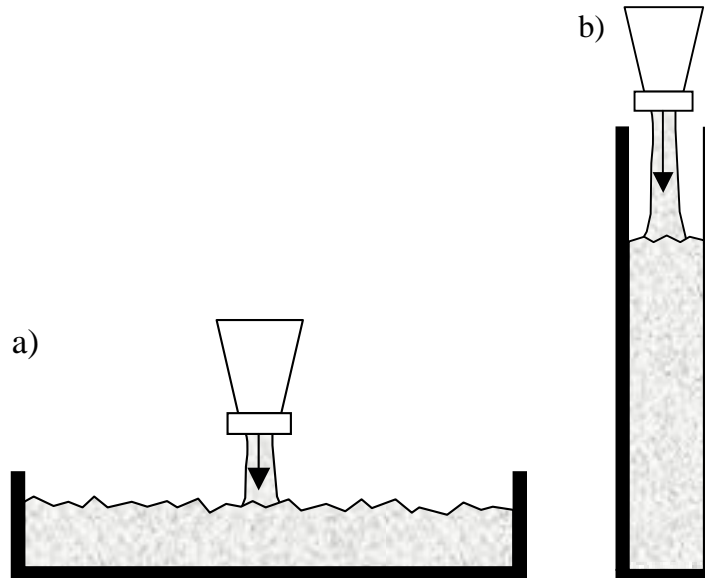

Figure 2.1.1: Specimens cast in the correct position; a) wall or ceiling; b) wall

2.1.4 Loading

The compressive loading which exists in practice shall also be applied to the specimen. In the specimen a uniformly distributed compressive loading shall be applied. The value of the compressive stress shall be equal to the maximum compression level of the fire exposed surface of the actual tunnel structure.

In most cases it is possible to do this by means of internal post-tensioning. To achieve this, steel ducts should be incorporated in the specimen before the concrete is cast. The anchorage of the pre-stressing rods or strands should be carefully designed, providing anchorage cones and splitting or coil reinforcement or anchor blocks for a uniform load distribution.

The compression level in the specimen should be equal to the compression level of the fire exposed surface of the real tunnel. It is allowed to apply eccentric compression to the specimen as long as the compression of the fire exposed surface matches the real tunnel and the eccentricity is not greater than in reality.

The exact positioning of the pre-stressing ducts is important. Especially when external anchor blocks are used, the positions of the ends of the ducts shall be within a tolerance of max. 5 mm, in order to achieve a constant load on the test specimen and to prevent loss of pre-stressing due to friction.

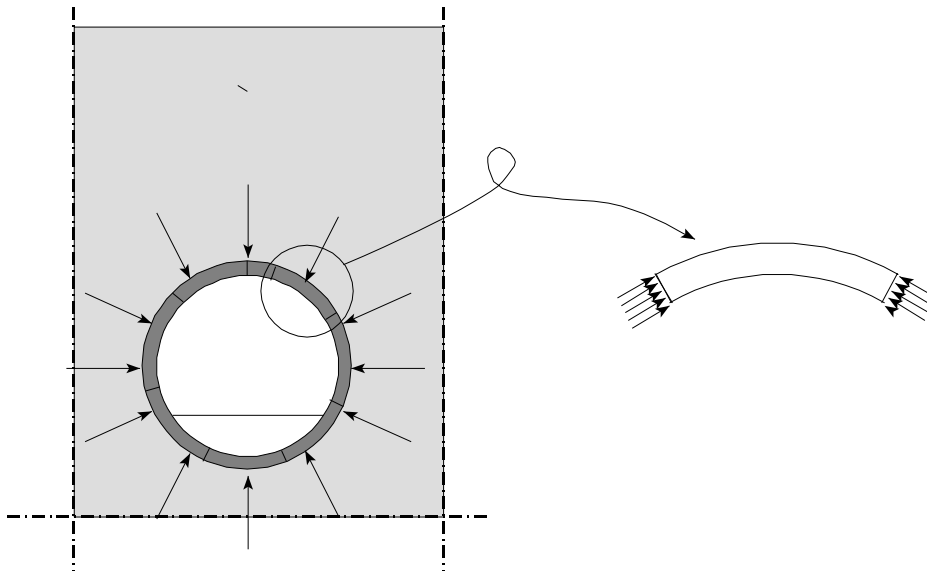

Figure 2.1.2: Principle of representing compressive ring forces by prestressing

2.1.5 Concrete mix

The concrete mix as used in practice shall also be used for the test specimens. This includes aggregate types and sizes, cement type and quantity, water cement ratio, possible micro-fillers, type and dosage of polypropylene fibres etc.

2.1.6 Temperature measurements

A spalling test aims to establish whether or not spalling occurs. Therefore in principle it is not necessary to measure concrete temperatures. Nevertheless it is highly recommended to measure the temperatures in a number of locations (reinforcement, concrete surface, etc.). This may also be required by the client, especially if thermal criteria are imposed on top of the criteria concerning spalling. If it is chosen to apply thermocouples in a spalling test than the same principles which apply for thermal insulation tests also apply for the spalling test.

In each concrete specimen a number of thermocouples have to be applied by Efectis Nederland before casting of the concrete. Dependent on the size of the specimen and other project specific requirements, approx. 10 thermocouples will be positioned on the lower reinforcement (seen from intrados). If an external layer of insulation material will be applied, a similar number of thermocouples will be applied to the concrete surface or interface. If required, additional information can be obtained by applying extra thermocouples at other depths.^{iv} It is recommended to apply some thermocouples to post-tensioning ducts to be able to monitor the temperature of the strands/rods during the test.

The positioning and fixing of the thermocouples shall be done in such a way that it does not disturb the measurement values and that the thermocouple does not move during casting of the concrete. Therefore it is recommended to fix thermocouples to reinforcement bars. If no reinforcement bar is present it is recommended to add a small diameter (e.g. 6 mm) reinforcement bar, parallel to the exposed surface, to which the thermocouple can be fixed. Otherwise the thermocouple is very likely to move during casting, which influences the result much more than the 6 mm rebar.

The thermocouples - of the type chromel-alumel - must have characteristics appropriate to the range of temperatures to be measured.

2.2 FIRE PROTECTION SYSTEM

If it is intended to apply an external fire protection system in the practical situation, this system should be part of the test specimen. This paragraph describes how the fire protection system should be applied on the concrete test specimen in order to be representative for the practical situation.

A number of external fire protection systems are available:

- spray mortar;
- pre-cast mortar (insulation material poured in the formwork before casting of the concrete);
- post-fixed boards;
- pre-fixed boards (insulation material applied in the formwork before casting of the concrete);
- systems which combine fire resistance with other functions (e.g. fire resistant linings which also serve as a leakage water drip shield, acoustic lining, etc.).

With respect to the protective material the supplier must offer Efectis Nederland - on a confidential basis - at least the following information:

- the nature of the different components of the material;
- the mass ratio of the mixture ingredients (in kg/m^3);
- the official name of the material.

Positioning of the concrete slab during application of the fire protection

When it is expected that the position of the concrete slab in the real tunnel affects the way the fire protection system is applied to the concrete, the position of the concrete slab shall be representative for that situation. E.g. spray mortar in a real tunnel will be applied to the ceiling and walls. Application to the ceiling is the most difficult so in the lab the slab shall be positioned horizontally with the surface to be protected at the underside.^v

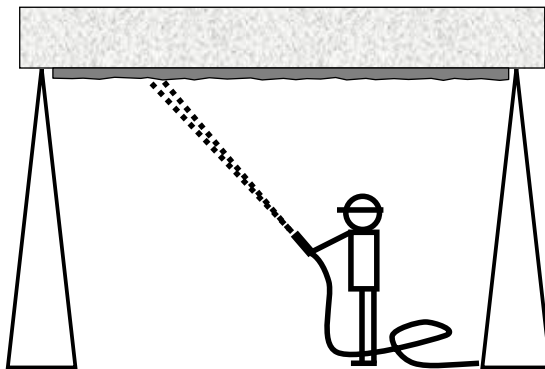

Figure 2.2.1: Overhead spraying of spray mortar

Depending on the geometry of the specimen, it may be required to apply fire protection also to the sides of the specimen, to avoid heating of the sides of the specimen due to leakage of hot air.

Joints between boards

The protection system shall exist of board panels with joints of the type intended to be used in practice (butt joint or rebated joint, see figure 2.2.2).

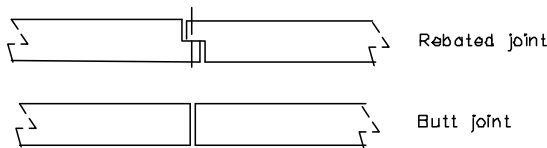

Figure 2.2.2: Joint types

Requirements for the reinforcement and anchorage of protective materials

All fire protection materials shall be applied to the concrete in such a way that the protective material, when used in practice, will not fall down during tunnel operation and during a fire. The anchoring system (direct bonding, anchors, wire mesh etc.) is the supplier’s choice. The system that is tested must be equal to the system to be applied in the tunnel.

The bonding of spray mortars to the surface is strongly influenced by the surface treatment of the concrete before spraying. If the concrete surface is roughened e.g. by high pressure water jet washing, the test result is only valid for tunnel situations in which the concrete is treated to the same surface roughness. Also the cleaning of the concrete before applying the spray mortar shall be the same in the test specimen as in the real tunnel situation.

If anchors are used to fix the material (board, spray mortar) to the concrete, the fixing pattern should resemble the real tunnel situation as closely as possible:

- the same number of anchors per square meter (for boards: on the largest of the two panels);
- the same core to core distance between two anchors;
- the same distance between anchors and board joints (boards only).

When deciding on the anchor pattern for the test specimen, this pattern requires approval by the client.

If a wire mesh is used to fix a spray mortar to the concrete, the same type of wire mesh (mesh size, diameter, shape, etc.) shall be applied in the test specimen as in practice.

Thickness of protective materials

When applying a spray mortar a few small markers may be applied to indicate the right layer thickness. Such markers should be plastic or wood, because a steel marker might in fact anchor the spray mortar to the surface.

The thickness of the protective material shall be measured as follows.

- sprayed material and pre-cast mortar (in wet condition):
 - on the test slab/lining element: measurement in a grid of maximum 300x300 mm² and minimum total of 25 measurement points, with measurement points including the thermocouple locations;
- board materials:
 - before applying of the protection on the test slab/lining element measurements shall be taken at least at 4 locations.

The thickness mentioned in the report will be the mean thickness, as well as the minimum and maximum values and a standard deviation based on a normal distribution. A 95% characteristic upper limit thickness is equal to the average measured thickness + t *standard deviation, where t can be found in table 1.

Table 1: t -values for a 95% characteristic value based on the Student’s t -distribution

Number of measurements	t
≥ 25	1.708
≥ 40	1.684
≥ 60	1.671
≥ 100	1.660

Steel fixings of installations in the tunnel

In most tunnels, installations such as jet fans, traffic lights, etc. are fixed to the ceiling. If a steel anchor penetrates the fire protective layer, the heat is easily conducted into the concrete. Also if PP-fibre concrete is used, the steel anchors will conduct the heat deeper into the concrete.

Little conclusive information is available as to the appropriate configuration of such fixings, but any fixings with bolts with a diameter of more than 8 mm is suspect to negatively influence the spalling behaviour.

Such configurations should be tested to evaluate whether or not spalling occurs. In order to simulate the stresses in the concrete around the steel anchor it is recommended to apply a load to the fixing which represents its intended use.

Other requirements for fire protection systems

Besides fire resistance, other properties of a fire protection system may also be relevant. Such properties include frost/thaw resistance, fatigue strength, pressure wave resistance, resistance against de-icing salts, etc. These aspects are not considered in this document.

It is recommended to the client to store some extra samples of the fire protection system (including the insulation material as well as fixings), in order to enable future verification of the tested products.

2.3 CONDITIONING OF THE TEST SPECIMENS

Samples for determination of the moisture content

It is important to execute the tests with a moisture content which represents the actual situation during operation of the tunnel. It is important that the insulation material is not too wet, because this has the effect of slowing down the temperature rise in the insulation material and, more important, also in the concrete.

Each fire test specimen shall be accompanied by at least the following test samples:

- a) One sample of the protective material as specified in figure 2.3.1 (spray mortar only)
- b) Two samples of concrete and protective material as specified in figure 2.3.2.

ad a)

This sample is needed to monitor the moisture content of the insulation.

A steel tray must be sprayed in a horizontal position and in the same direction as the test slab/lining element, and to the same spray mortar thickness. The tray shall be weighed before and directly after the application of the sprayed protective material. After spraying, the tray shall be stored together with the test specimen. The tray will be weighed at regular intervals, to monitor the decreasing moisture content of the insulation material.



Figure 2.3.1: Steel tray with spray mortar

ad b)

This sample is needed for the final determination of the moisture content and density of the insulation material and the concrete.

- For post-fixed boards, the sample can be a piece of board from the same batch as used for protecting the specimen. The piece of board shall be at least 300x300 mm². Also, a small concrete slab (measuring 400x400x150 mm³) shall be provided in order to measure the moisture content of the concrete. The vertical sides and bottom of the concrete specimen shall be prevented from drying, e.g. by leaving a formwork around the small slab.
- For post-applied spray mortars, the sample consists of a small concrete slab (measuring 400x400x150 mm³) protected with the intended mean thickness of insulation material. The slab shall be protected by spray mortar in the same way as the fire test specimen but without wire mesh reinforcement. The vertical sides and

bottom of the specimen shall be prevented from drying, e.g. by leaving a formwork around the small slab.

- For pre-fixed materials, the sample consists of a small concrete slab (measuring 400x400x150 mm³) protected with the intended mean thickness of insulation material. The small slab shall be produced by casting the concrete on top of the pre-applied material. The vertical sides of the specimen shall be prevented from drying, e.g. by leaving a formwork around the small slab.



Figure 2.3.2: Concrete sample in its formwork, with spray mortar applied to the top surface

Drying time

The concrete specimen shall be sealed by plastic foil after removing the formwork, in order to achieve a moisture content which will be on the conservative (high) side compared to the real situation.^{vi} The plastic foil shall be removed just before fire testing. In case of a sprayed insulation material the plastic foil on the bottom side shall stay until the moment the application of the insulation material starts. The application of the spray mortar may commence at a concrete age of at least 28 days.

The fire test shall not take place before both the concrete and the protective material have reached the following conditions:

- The concrete specimen shall be at least 90 days of age in order to achieve a sufficiently mature micro-structure.ⁱ
- Average moisture content of insulation materials: in principle $\leq 5\%$ (m/m); a higher moisture content is only allowed if the supplier can prove that this will be the case in practice. Please note that for commonly used spray mortars the drying time needed to reach this level may be more than two months (depending on storage conditions and insulation thickness).^{vii}

Record shall be made of the conditions (temperature and humidity) under which the test specimens are stored (this with a view to create reproducible conditions in the case more testing is necessary).

For a test on a concrete specimen protected by post-fixed or pre-fixed boards or sprayed materials it is allowed to speed up the process of drying of the insulation material by artificial means (slightly increased temperature, low relative humidity). However, special attention should be paid to the concrete slab, because a dry slab will be less prone to spalling and therefore does not represent a conservative case.

The heating should remain below a level which is not detrimental to the insulation material (e.g. max. 40°C). Moreover, for spray mortars it is required to wait at least 28 days after spraying before accelerated drying is started, because the strength of the mortar and the bond strength of the mortar to the concrete need to be fully developed first. Also, the accelerated drying should not be prolonged for more than 28 days.

Table 2: time schedule of the preparation of a fire test

	Time [days]	Activity
t ₀	-	Casting of the concrete specimen
t ₁	t ₀ < t ₁ < t ₂	Demoulding, wrapping the specimen in plastic foil
t ₂	t ₂ ≥ t ₀ + 28	Removal of plastic foil and application of fire protection
t ₃	t ₃ ≥ t ₁ + 28	Initiation of accelerated drying of spray mortar (max. 40°C unless proven otherwise)
t ₄	t ₄ ≤ t ₃ + 28	End of accelerated drying
t ₅	probably t ₅ ≥ t ₂ + 60	Fire protection has reached equilibrium moisture content (max. 5% by mass unless proven otherwise)
t ₆	t ₆ ≥ t ₀ + 90 and t ₆ ≥ t ₅	Fire test

Final determination of the average moisture content

Two dummy slabs measuring 400x400x150 mm shall be made with each concrete specimen, using the same concrete mix composition. These dummy slabs shall be treated the same as the test specimen at all times. When the spray mortar is applied to the test specimen, an equal thickness of spray mortar shall be applied to each dummy slab.

Insulation material

Small dry-cut core samples from the spray mortar shall be taken from one of the dummy slabs some days (but not more than one week) before the planned date of the fire test. The core samples of the protective material shall be weighed, then dried in an oven during 24 hours at (105 ± 5)°C²⁾ and be weighed again.

For board materials, a board sample will be weighed and dried in the same manner.

The average moisture content shall be calculated as follows:

$$\text{Moisture content in \% m/m} = (W_w - W_d) / W_d$$

where:

W_w is the weight of the core sample before drying;

W_d is the weight of the core sample after drying.

Concrete

Core samples of the concrete, with a diameter of approx. 50-100 mm, shall be taken from the other dummy slab some days (but not more than one week) before the planned date of the fire test. The core sample of the concrete shall be weighed, then dried in an oven during 168 hours at (105 ± 5)°C and be weighed again, and the moisture content shall be calculated according to the same formula.

Determination of the density of the protective material at the date of the fire test

The density ρ shall be determined on the basis of the weight and dimensions of a sample of the fire protection material. A sample of at least 100x100 mm² (and thickness as applied) should be taken from the dummy slab for this purpose. The sample should be weighed, dried during 24 hours at 105°C and weighed again.

Both the original (moist) density and the dry density shall be calculated.

Determination of the density of the concrete at the date of the fire test

The moist density of the concrete shall be calculated by means of the weight and dimensions of the same core as used for determination of the moisture content of concrete. Both the original (moist) density and the dry density shall be calculated.

² Not applicable for gypsum boards.

2.4 FIRE TEST

The specimen shall be placed on the furnace in the same orientation as the position of the structural element it represents. I.e. a wall specimen shall be tested vertically, a ceiling specimen shall be tested horizontally.^{viii}

- ❑ A horizontal test result (exposed side down) is valid for both horizontal and vertical applications.
- ❑ A vertical test result is only valid for a vertical application.

Examples of tests and the structures for which they are considered representative, are given in figures 2.4.1 to 2.4.3.

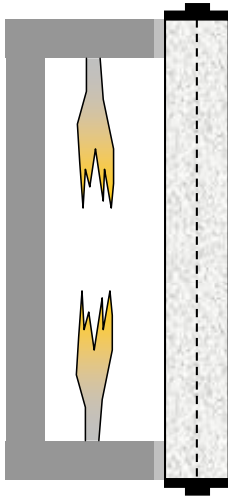

Figure 2.4.1: Vertical test, representing the tunnel walls

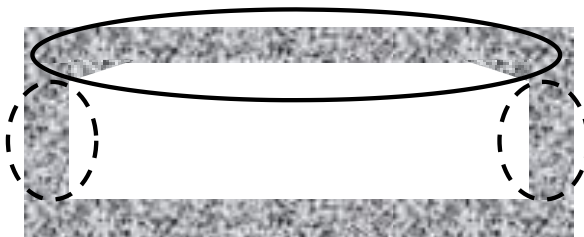
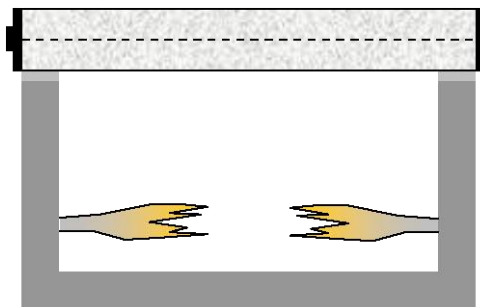

Figure 2.4.2: Horizontal test, representing a tunnel ceiling but also conservative for the walls

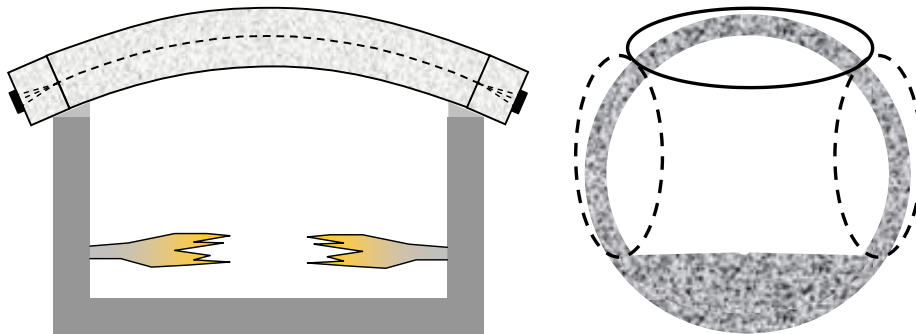

Figure 2.4.3: Test on a curved tunnel segment, representing a bored tunnel ceiling but also conservative for the bored tunnel walls

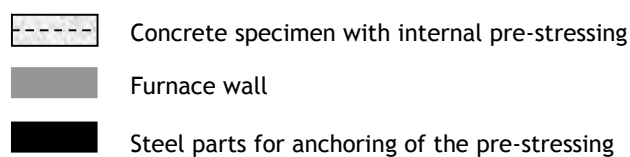

Figure 2.4.4: Legend for figures 2.4.1 - 2.4.3

2.5 HEATING CURVE

The heating of the furnace shall be according to the prescribed fire curve. RWS has specified their requirements for tunnels and other subsurface road structures in the document ROBK-6. In ROBK-6, the fire duration and the temperature time curve depends on the type of the tunnel. For under water tunnels, a fire test according to the RWS fire curve for 120 minutes is required.

Table 3: RWS fire curve

Time [min.]	Temperature [°C]
0	20
3	890
5	1140
10	1200
30	1300
60	1350
90	1300
120	1200
>120	1200

Depending on the situation, authorities can prescribe another fire curve and they may also add a prescribed cooling down phase if they expect significant temperature penetration or other physical effects during the cooling down phase.

The gas temperatures in the furnace shall be measured with furnace thermocouples as specified in NEN 6069, placed at approximately 200 mm from the bottom of the protective material. For a spalling test the number of furnace thermocouples shall be between ½ and 1 times the exposed surface area of the specimen in square meters.

The percentage deviation d_c , in the area under the average time-temperature curve recorded by the specified furnace thermocouples, from the area under the prescribed time-temperature curve shall be within:

$$\begin{aligned}d_c \leq 15 \% & \quad \text{for} \quad 5 < t \leq 10 \\d_c \leq 10 \% & \quad \text{for} \quad 10 < t \leq 30 \\d_c \leq 5 \% & \quad \text{for} \quad 30 < t\end{aligned}$$

$$\text{where } d_c = \frac{A - A_s}{A_s} * 100$$

in which:

d_c is the percentage deviation

A is the area under the actual furnace temperature-time curve in °C

A_s is the area under the prescribed temperature-time curve in °C

t is the time in minutes

All areas shall be computed by the same method, i.e. by the summation of areas at intervals not exceeding 1 minute and they shall be calculated from time zero.

At any time after the first 10 minutes of the test, the temperature recorded by any thermocouple in the furnace shall not differ from the corresponding temperature of the prescribed temperature-time curve by more than 100°C. During the cooling-down phase, this tolerance is only required for temperatures down to 400°C.

If spalling of concrete occurs, the temperatures in the furnace will be reduced due to the ongoing exposure of new, cold, concrete surfaces. In that case it cannot be guaranteed that the furnace temperature remains within the tolerances.

Efectis Nederland reserves the right to stop the test whenever it is considered unsafe to continue, e.g. because of severe spalling of concrete, heating of the post-tensioning steel or (near) collapse.

2.6 PERFORMANCE CRITERIA

The objective of this document is to provide a uniform fire testing procedure for concrete tunnel structures. The actual required performance in such tests is a decision of the client. In general, performance requirements could include:

- maximum values for the concrete surface temperature
- maximum values for the steel reinforcement temperature (to be measured on the side of the steel bar which is closest to the fire exposed concrete surface)
- maximum values for the temperature at another depth in the concrete structure
- maximum allowable spalling depth, or simply “no spalling”.

RWS has specified their requirements for tunnels and other subsurface road structures in the document ROBK-6. The temperature requirements in ROBK-6 depend on the type of tunnel and the part of the structure (compression zone or tension zone). For concrete under compression in an underwater tunnel, the requirements are

- $T < 250^\circ\text{C}$ for the steel reinforcement.
- $T < 380^\circ\text{C}$ on the concrete surface for underwater tunnels^{ix}.

For concrete under compression in other tunnels, the requirements are

- $T < 250^\circ\text{C}$ for the steel reinforcement.
- $T < 380^\circ\text{C}$ for the concrete within 25 mm from a reinforcement bar^x.

Moreover, spalling of concrete is never allowed to be more than superficial.

For each of the requirements it is advisable to specify the number of measurement points and the handling of scatter in results. For temperature measurements this means that the number of thermocouples at a certain depth should be prescribed, along with a statistical approach e.g. to use a 95% characteristic value of all measured temperatures at a given time. Also it is recommended to prescribe a minimum of thermocouples that should function correctly during

the test.

For measurement of the spalling depth, the intermediate distances of the measurement grid should be specified (e.g. a grid of max. 25x25 cm) along with a statistical approach e.g. to use a 95% characteristic value of all measured spalling depths. Also, it could be specified that spalling depths should not be measured close to the sides of the specimen, because the spalling depth is often less due to edge effects.

2.7 REPORT

The test report shall contain the following information:

- a) the name of the tunnel project for which the test specimens are representative;
- b) the name and address of the supplier;
- c) the date of the test(s);
- d) the name of the manufacturer of the protective material and the trade name of the product (or components) together with identification marks as well as a global description of the composition;
- e) construction details of the test slabs, i.e. a description, drawings and the exact position of the thermocouples as well as a statement concerning the Efectis Nederland's involvement in the manufacturing of the test slabs;
- f) the method of applying and fixing the protective material on the test slabs;
- g) details and dates with respect to the manufacturing and conditioning of the test slabs and test samples;
- h) the measured thickness, densities and moisture content of the protective material;
- i) the measured temperatures in the furnace and in the test slabs;
- j) the conclusion with respect to the performance criteria;
- k) for sprayed materials the report must also include or refer to the supplier's/manufacturer's directions for application and the conditions for application in practice (such as a qualified sprayer, spraying equipment, spraying distance etc.) to guarantee the quality of the material;
- l) the measured spalling depths;
- m) a description of observations with regard to the nature of the spalling process (time of occurrence, noises, visible effects).

Besides providing a test report, Efectis Nederland will deliver a video-DVD recorded inside the furnace. Such a video can provide useful understanding of the actual structural behaviour during a fire.

3. THERMAL INSULATION TEST

A thermal insulation test serves to prove the thermal insulating capacity of a fire protection system. This type of test is not linked to a specific tunnel project. The test results can be used for any given tunnel. However, if the concrete structure of a specific tunnel is expected to be sensitive to spalling, a project related spalling test must be done, see chapter 2.

Alternatively, a thermal insulation test can also be carried out on unprotected concrete if previous research has already proven that this concrete type does not spall. The test then serves to demonstrate the reinforcement temperatures given the thickness of the concrete cover.

The test result does not provide any answers with regard to spalling of concrete, because the concrete specimen is simplified to a simply supported slab, without taking into account all other conditions (geometry, loading, conditioning, etc.) that can influence spalling. If the test aims to demonstrate spalling behaviour or spalling resistance, spalling tests according to chapter 2 should be done.

The thermal insulation test procedure described in this chapter corresponds with the “standard fire test for immersed tunnels (concrete slab with the protective insulation)” which was earlier described in TNO report 1998-CVB-R1161 (rev.1) - “Fire Protection for Tunnels - Part 1: Fire Test Procedure”. Concrete slabs test reports according to 1998-CVB-R1161 (rev.1) therefore are automatically in accordance with the provisions of this chapter.

3.1 TEST SPECIMENS

The concrete slabs used for the application of the fire protection and the fire tests shall have dimensions of at least 1450 x 1450 mm and a nominal thickness of 150 mm.

At the top and bottom each of the slabs has to be provided with a reinforcement mesh Ø12-200 mm (see figure 3.1.1) and a concrete cover of 25 mm.

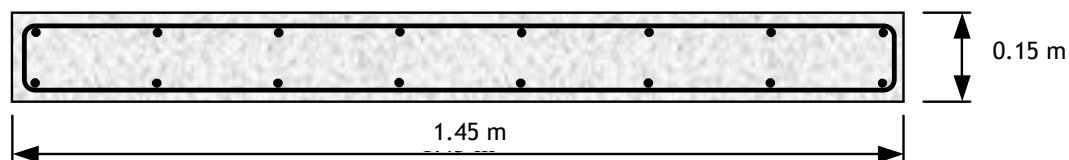

Figure 3.1.1: Cross section of the test specimen

The specifications of the concrete of the slabs are as follows:

- Strength class (according to NEN 8005): C28/35;
- Environment class (according to NEN 8005): XD3;
- Consistency class (according to NEN 8005): Slump class S2;
- Cement: Blast furnace cement CEM III/B 42,5 LH HS, 320 kg/m³;
- Aggregate: Sand and gravel, $D \leq 31.5$ mm;
- Water-cement ratio: approximately 0.45.

In each concrete slab a number of thermocouples have to be applied by Efectis Nederland before casting of the concrete. 8 thermocouples will be positioned on the concrete surface. If a non-standard concrete mix is to be used, it may be required to apply another 8 thermocouples at the lower reinforcement. If required, additional information can be obtained by applying extra thermocouples at other depths.

The positioning and fixing of the thermocouples shall be done in such a way that it does not disturb the measurement values and that the thermocouple does not move during casting of the concrete. A good method to measure reinforcement temperatures is by positioning the thermocouple wire parallel to the rebar and fix it using small pieces of plastic tape. In any

case, a thermocouple wire length of at least 25 mm near the measurement tip of the wire should be placed parallel to the fire exposed surface.
The thermocouples - of the type chromel-alumel - must have characteristics appropriate to the range of temperatures to be measured.

3.2 FIRE PROTECTION SYSTEM

The provisions of 2.2 apply. An important objective of the fire test is to evaluate if the fire protection system remains intact during the exposure to fire (e.g. 1350°C) and if the tested thickness provides sufficient insulation capacity.

When testing a fire protection board system, the protection system shall exist of two boards (panels A and B). In this way, the influence of a joint between the boards can be evaluated. Three of the thermocouples at the concrete surface shall be positioned directly behind the joint. The two boards protect the area which will be exposed to fire (approx. 1,15x1,15 m²). The size of the slab is at least 1,45x1,45 m² so there is an edge of 0,15 m. This edge shall also be protected, by strips of the same material. Along the edges of the test specimen a butt joint shall be realised with a gap of approximately 1 mm to enable the panels A and B to fall down during the heating (see also figure 3.2.3).

If the boards are fixed using anchors with a diameter of maximum 6 mm, it is not required to measure the concrete surface temperatures near the anchors. If larger diameter anchors are foreseen, it should be considered that these may cause a significant heat leakage into the concrete and therefore it may be required to measure the temperatures near the anchors.

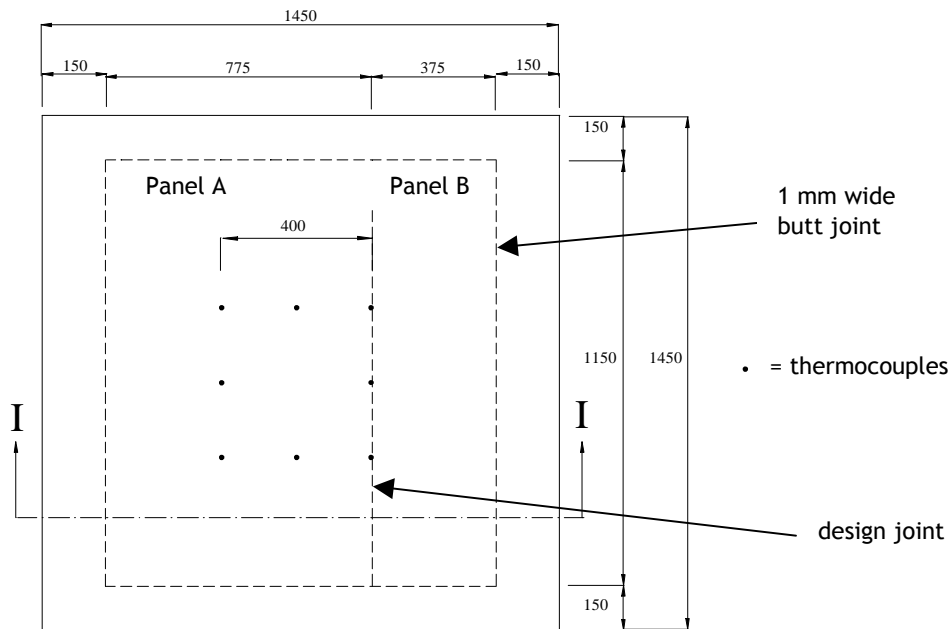

A. Top view

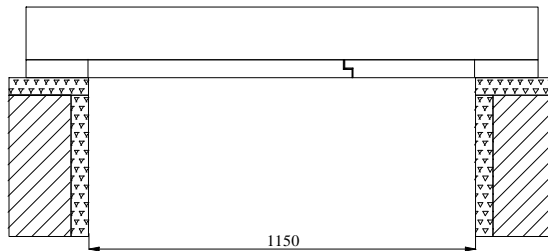

B. Cross section I-I: slab with board insulation material

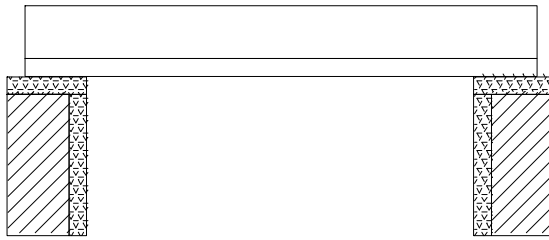

C. Cross section I-I: slab with sprayed insulation material

Figure 3.2.3: 1.45x1.45 m² test specimen with 1.15x1.15 m² exposed to fire

3.3 CONDITIONING OF THE TEST SPECIMENS

The provisions of 2.3 apply. Additionally, it is required that the moisture content of the concrete by mass with respect to the dry weight shall be $\leq 4\%$.^{xi} The concrete specimen does not need to be at least 90 days of age.

For the thermal insulation test for post-fixed or pre-fixed boards and sprayed materials it is allowed to speed up the process of drying of the insulation material by artificial means (slightly increased temperature, low relative humidity) with no special attention to the concrete slab, for instance by heating below a level which is not detrimental to the insulation material. However for spray mortars it is recommended to wait at least six weeks after spraying before artificial drying is started, because the strength and bonding of the mortar to the concrete needs to be fully developed first.

3.4 FIRE TEST

The test slab shall be placed horizontally on top of the furnace and directly heated at its bottom. The exposed surface will be approximately 1150x1150 mm².

3.5 HEATING CURVE

The provisions of 2.5 apply, but the gas temperatures in the furnace shall be measured with at least 3 furnace thermocouples.

3.6 PERFORMANCE CRITERIA

The objective of this document is to provide a uniform fire testing procedure for concrete tunnel structures. The actual required performance in such tests is a decision of the client.

RWS has specified their requirements for tunnels and other subsurface road structures in the document ROBK-6. The temperature requirements in ROBK-6 depend on the type of tunnel and the part of the structure (compression zone or tension zone). For concrete under compression in an underwater tunnel, the requirements are

- $T < 250^{\circ}\text{C}$ for the steel reinforcement.
- $T < 380^{\circ}\text{C}$ on the concrete surface for underwater tunnels^{ix}.

For concrete under compression in other tunnels, the requirements are

- $T < 250^{\circ}\text{C}$ for the steel reinforcement.
- $T < 380^{\circ}\text{C}$ for the concrete within 25 mm from a reinforcement bar^x.

It is recommended by Efectis to define the temperature T as a 95% characteristic value of all temperature measurement positions at a given level. Moreover, at least 6 thermocouples at each measurement level should function correctly during the test. At any given point in time, T can be calculated as being the average temperature + t *standard deviation, where t can be found in table 4.

Table 4: t-values for a 95% characteristic value based on the Student's t-distribution

Number of measurements	t
6	1.943
7	1.895
8	1.860
9	1.833
10	1.812
15	1.753
>20	1.725

If multiple tests have been done on the same system with different insulation layer thickness, linear interpolation for intermediate thickness values and corresponding temperatures is allowed.

3.7 REPORT

The test report shall contain the information specified in 2.7 except for items a, l and m. A video-DVD will only be produced on special request.



Ir. A.J. Breunese



Dr. Ir. C. Both

APPENDIX A: NOTES CONTAINING BACKGROUND INFORMATION

ⁱ Spalling is strongly dependent on the microstructure of the concrete. The generally accepted age of 28 days for determination of e.g. the compressive strength is insufficient for a spalling test. After 28 days, hydration of the cement will still continue and the microstructure of the concrete will change. The effect of ageing on the microstructure of the concrete is strongly dependent on the mix (cement type, micro-fillers, etc.). By lack of detailed information on the influence of concrete ageing on spalling, a value of 90 days is recommended as a minimum age for concrete specimens to be used in a spalling test.

ⁱⁱ Moreover, if a wet concrete slab is used for the test, it will absorb more thermal energy and therefore heat up slower than a dry slab.

ⁱⁱⁱ Spalling is very difficult to predict, because many parameters play a role and the combined effects of these parameters can be surprising. Also, small changes in assumptions may lead to a very different result. Therefore it is necessary to confirm that the obtained test-result is reproducible.

^{iv} The temperature measurements inside the concrete only give additional information, but there is usually no requirement related to it. Such additional information may serve to know when spalling occurs during the test (sudden increase of concrete temperatures) or to improve the design of the tunnel lining in case the test should fail.

^v Spraying in a laboratory is generally different from spraying in a tunnel. In tunnels, spraying is often done by a robot whereas in the laboratory the spraying is done manually. Moreover, fire tests are usually done in an early phase of the project, when the spraying robot is not yet operational.

^{vi} The moisture content in the tunnel will be dependent on climate, season and weather effects as well as the use of the tunnel. Therefore it is hard to predict which moisture conditions are representative for the tunnel. Since moisture inside the concrete is one of the main factors influencing spalling, a high moisture content is considered conservative. Also, the test result should be reproducible. Therefore it is chosen to wrap the concrete in plastic foil. In this way, the concrete will retain its original moisture content.

^{vii} The moisture content of the insulation material has a major influence on its insulating capacity. Therefore the moisture content of the insulation material should be less than or equal to the moisture content in the tunnel. 5% by mass is considered a safe value, but for specific materials it may be shown on basis of measurements in real tunnels that this percentage can be higher.

^{viii} This is important because gravity may influence the spalling process. It is conservative to test horizontally with the exposed side down, because in that case gravity will pull loose pieces of concrete away from the specimen.

^{ix} Historically the reason for the limitation of the concrete temperature is the fact that at high temperatures, irreversible damage occurs in concrete. Recent research developments have raised awareness of the fact that thermal cracks propagate into the cold zone, probably all the way to the cold surface, and that these cracks may also occur at concrete temperatures below 380°C. It is likely that this criterion will be revised in the future when more information on such cracking behaviour becomes available.

^x The reason for the latter criterion is the assumption that the reinforcement can only contribute to the load bearing capacity when it is surrounded by 25 mm of “healthy” concrete.

^{xi} The moisture content of the concrete influences the temperature development inside the slab during the test. A high moisture content will slow the heating rate of the concrete surface. In order to do a conservative test, the concrete slab has to be sufficiently dry.